

LabVIEW Virtual Instrument for Modeling and Control of Three-Phase BUCK Rectifier with Sinusoidal PWM

Stoyan Aleksandrov Vuchev, Georgi Tzvetanov Kunov and Dimitar Damyanov Arnaudov

Abstract – The present paper considers a developed by the means of the LabVIEW software virtual instrument for modeling and control of three-phase BUCK rectifier with sinusoidal PWM. It generates control pulse sequences which can be used to control a rectifier via proper hardware and driver stages. The structure of the virtual instrument is presented. Results from its operation are obtained and compared to the ones from a simulation of the device via MATLAB Simulink. Apart from the control capabilities, this virtual instrument can be used for simulation of the operation of three-phase rectifiers with sinusoidal PWM as well.

Keywords – Virtual Instrument, LabVIEW, Three-Phase Rectifier, Sinusoidal PWM, Power Factor Correction.

I. INTRODUCTION

Three-phase rectifiers with sinusoidal PWM are used in order to improve the power factor of the devices. There are different power circuits for realization of three-phase rectifiers using combinations of transistors and diodes as power switches [1, 2, 3, 4, 5].

Circuit of the considered rectifier is presented in fig. 1. It is realized by a conventional three-phase bridge with six unidirectional switches ($VD1, VS1 \div VD6, VS6$). Its control unit consists of driver stages, CDAQ frame with TTL input-output module and the developed virtual instrument.

Different control algorithms for three-phase rectifiers are known. One of them is illustrated in [6]. By analogy to this algorithm, a MATLAB Simulink model of the investigated rectifier and its control unit is designed [7].

According to the algorithm characteristics, PWM sequences are obtained for each transistor via comparison between a sinusoid and a high-frequency saw-tooth signal. When one of the grid phase voltages is the most positive or negative compared to the other two, the corresponding switch conducts according to its own pulse sequence. Otherwise, its gate is controlled by the sequences for the prior and the next to conduct switches. Equations (1) and (2) illustrate this for the gate signals $G1$ and $G4$ of transistors $VS1$ and $VS4$:

$$G1 = R_MAX.R_POS \cup pwmSp.pwmTn.S_MIN.RLp \cup pwmTp.pwmSn.T_MIN.RLp \quad (1)$$

$$G4 = R_MIN.R_NEG \cup pwmSp.pwmTn.S_MAX.RLn \cup pwmTp.pwmSn.T_MAX.RLn \quad (2)$$

where $pwmXp$ and $pwmXn$ are the PWM sequences for the positive and negative side switches of the corresponding phase, X_MAX and X_MIN determine the most positive and negative phase voltage, and X_POS and X_NEG indicate the sign of these voltages.

$$RLp = \overline{R_MAX.R_POS} \quad (3)$$

$$RLn = \overline{R_MIN.R_NEG} \quad (4)$$

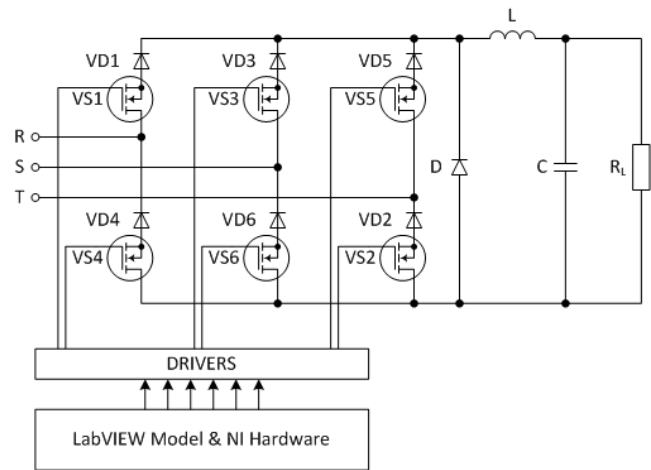

Fig. 1. Circuit of the considered rectifier.

By the means of the operation algorithm, a power factor correction can be obtained without using additional PFC circuits. When the output voltage of the considered rectifier varies from 0 to the maximum value, unlike with the conventional circuits of controllable rectifiers with thyristors, its power factor high values are maintained.

On the basis of the analysis in [7], a virtual instrument realizing the illustrated control algorithm is developed. It consists of two main parts – a Front Panel and a Block Diagram. The influence of the input filter on the circuit operation is not an object of the present analysis for both the MATLAB Simulink model and the developed virtual instrument.

St. Vuchev is with the Department of Power Electronics, Faculty of Electronic Engineering and Technologies, Technical University of Sofia, 8 Kliment Ohridski blvd., 1000 Sofia, Bulgaria, e-mail: vu4ev_100yan@abv.bg

G. Kunov is with the Department of Power Electronics, Faculty of Electronic Engineering and Technologies, Technical University of Sofia, 8 Kliment Ohridski blvd., 1000 Sofia, Bulgaria, e-mail: gkunov@tu-sofia.bg

D. Arnaudov is with the Department of Power Electronics, Faculty of Electronic Engineering and Technologies, Technical University of Sofia, 8 Kliment Ohridski blvd., 1000 Sofia, Bulgaria, e-mail: dda@tu-sofia.bg

II. VIRTUAL INSTRUMENT FOR MODELING AND CONTROL OF THREE-PHASE BUCK RECTIFIER WITH SINUSOIDAL PWM

A. Front Panel of the Virtual Instrument

Fig. 2. illustrates the Front Panel of the virtual instrument.

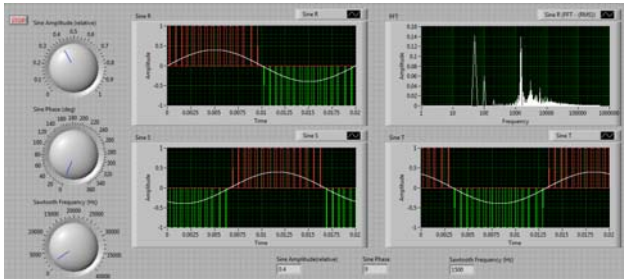

Fig. 2. Front Panel of the Virtual Instrument.

Graphical knobs are adjusted to the Front Panel in order to set the required depth of modulation (the sinusoid magnitude in relative values from 0 to 1), the saw-tooth frequency and the phase shift of the primary grid voltage (phase R). The values of these three parameters are displayed via numeric indicators at the bottom of the panel.

Graphical indicators are put as well for visualization of the shape of the control sequences required for the corresponding transistors for the positive and negative half period. These indicators allow visual perception of the controllable rectifier operation.

Another indicator illustrating the spectral composition of the generated PWM signals is also adjusted to the Front Panel. The displayed results allow determination of the input current spectral composition, which helps evaluating the rectifier power factor.

B. Block Diagram of the Virtual Instrument

The Block Diagram of the virtual instrument is presented in fig. 3. As it is a three-phase circuit, there are repetitive

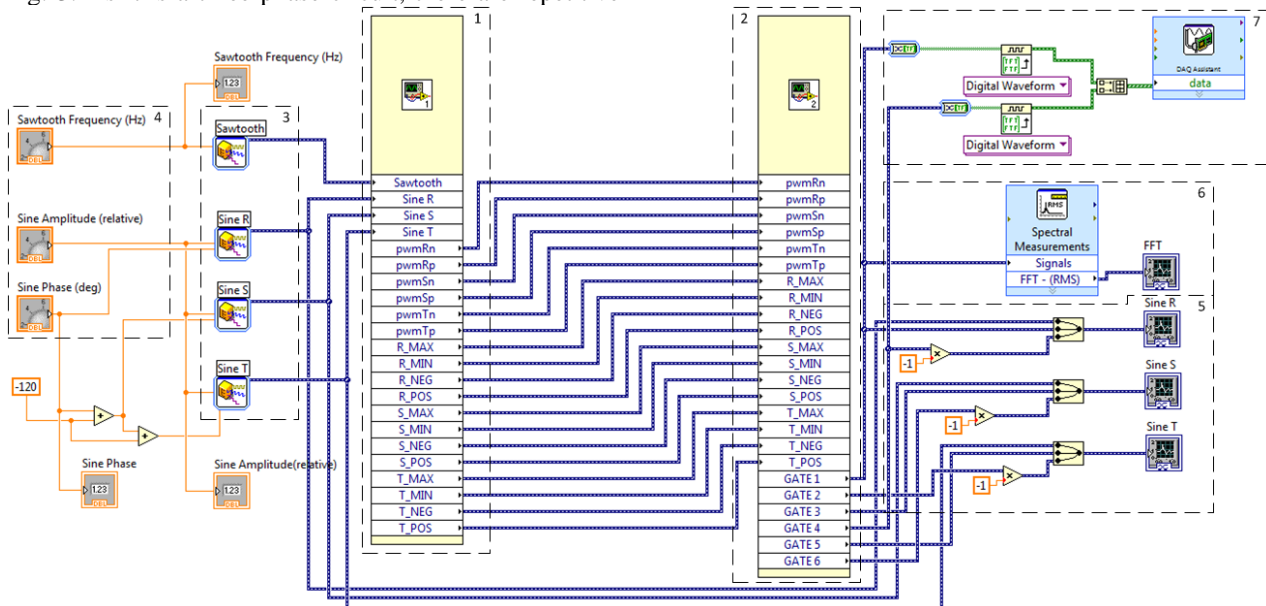

Fig. 3. Block Diagram of the Virtual Instrument.

elements which are realized as subunits (*subVI*). The Block Diagram consists of seven different units:

- *Unit 1 (subVI 1)* – this is the Signal Generation Block. Its main features are related to determination of the most positive and most negative phase voltage, indication of the sign of each phase voltage, as well as, generation of the primary PWM sequences for each of the rectifier transistors. Each of the three main functions is realized by a separate subunit as it is shown in fig. 4.

- *Unit 2 (subVI 2)* – this is the Signal Distribution Block. It realizes the logic responsible for the formation of the gate PWM sequences for each switch. This block consists of six identical subunits each of them corresponding to one of the power circuit transistors. The inner logic of the subunits is shown in fig. 5. The structure of the Signal Distribution Block is presented in fig. 6.

- *Unit 3* – this unit consists of three identical sine wave generators, as well as, a saw-tooth one. The frequency of the three sinusoids is fixed to the value of the grid frequency (50 Hz). The sinusoid labeled with R is admitted to be the primary one. Its phase can be set from the front panel. The other two (respectively S and T) are shifted at 120 degrees prior and next to R.

- *Unit 4* – it contains the three graphical knobs used to set the main operating parameters of the virtual instrument. The numeric indicators with their values are not marked as part of it but may be considered so.

- *Unit 5* – this unit consists of the three graphical indicators and the corresponding logic used to display the three sinusoids and the generated gate PWM sequences for the six transistors. The control signals for the even numbered switches (respectively for the negative half periods of the three phase voltages) are displayed inverted.

- *Unit 6* – it consists of the graphical indicator and the corresponding logic for spectral composition analysis of the generated PWM sequences.

- *Unit 7* – it contains the blocks realizing the connection between the virtual instrument and the hardware used to connect it to the rectifier power circuit.

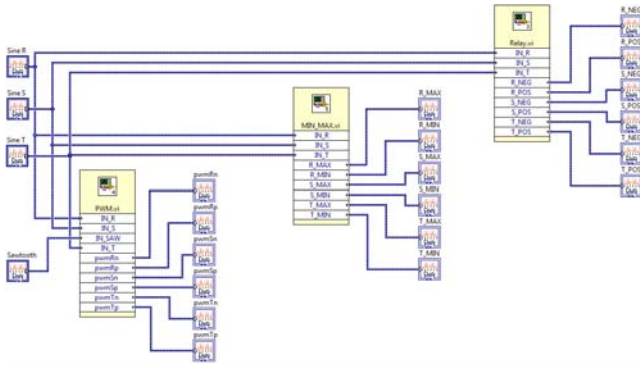

Fig. 4. Structure of the signal generation block.

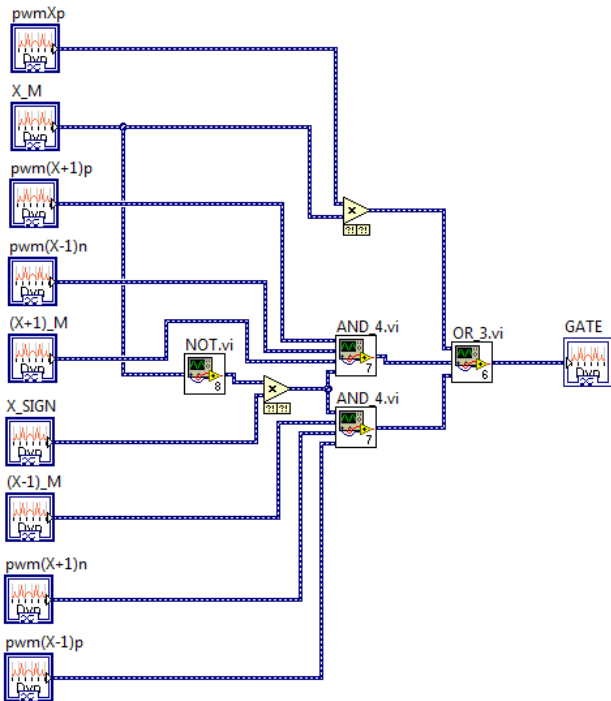

Fig. 5. Logic forming the gate PWM control sequences.

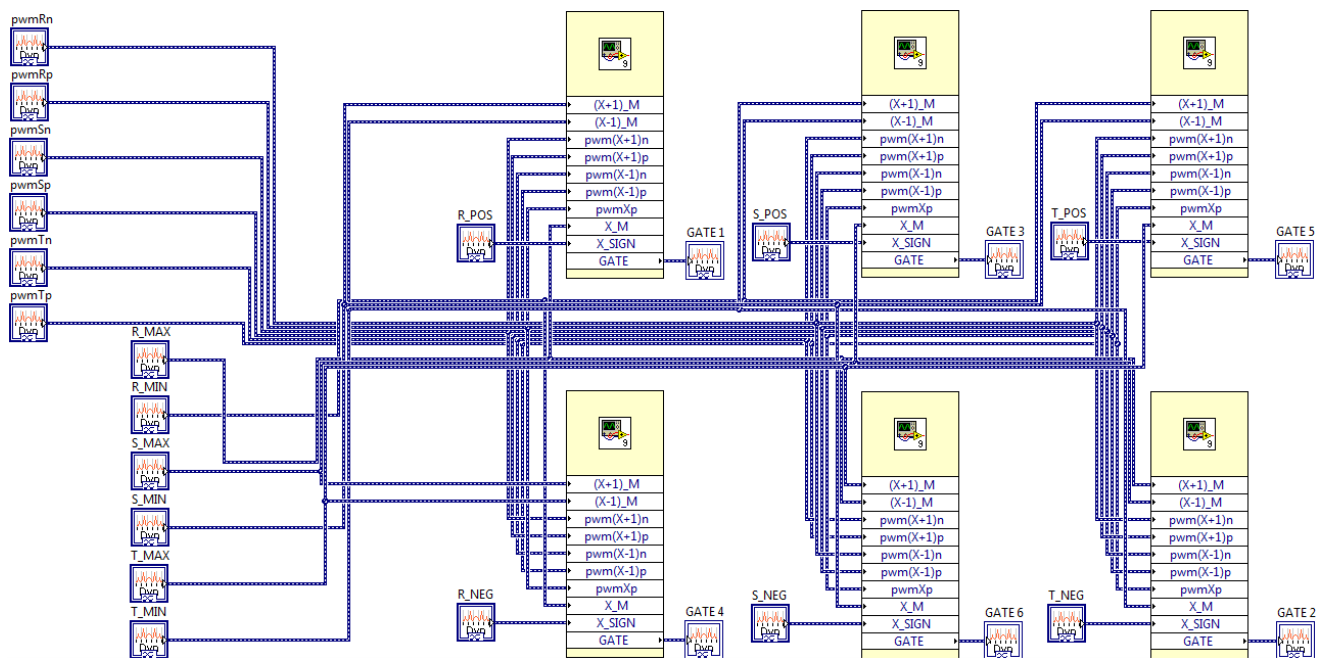

Fig. 6. Structure of the signal distribution block.

III. EXPERIMENTAL RESULTS

Experimental examinations of the developed virtual instrument are conducted using CDAQ frame NI9178 and programmable TTL input-output module NI9401. The control PWM sequences generated by the virtual instrument are observed with oscilloscope. They can be applied to a controllable rectifier via appropriate driver stages.

Fig. 7 and fig. 8 present the experimentally obtained waveforms of the gate signals $G1$ and $G4$, respectively for transistors $VS1$ and $VS4$. These waveforms prove one of the main advantages of the control algorithm – the switches operate during the whole time interval of the half period, which leads to consumption of currents in phase with the grid voltages.

IV. COMPARISON IN OPERATION BETWEEN THE LABVIEW AND THE MATLAB SIMULINK MODEL OF THE RECTIFIER

A comparative analysis of the two software models of the three-phase BUCK rectifier with sinusoidal PWM shows identical operation results for both of the models, which confirms the correctness of the developed LabVIEW instrument. The Front Panel of the virtual instrument can be supplemented with additional graphical indicators illustrating typical parts of the control algorithm and information analogical to the one presented in [7], which may enable the use of the virtual instrument for investigation and teaching purposes.

An advantage of the developed virtual instrument compared to the MATLAB Simulink model of the rectifier and its control unit is the ability to vary some of the operating parameters in real time via the graphical knobs from the Front Panel.

Fig. 7. Waveforms of the gate signals $G1$ and $G4$.Fig. 8. Waveforms of the gate signals $G1$ and $G4$.Fig. 9. Results from FFT analysis of signal $G1$ (LabVIEW).Fig. 10. Results from FFT analysis of signal $G1$ (MATLAB).

Fig. 9 and fig. 10 illustrate the spectral composition of the gate PWM sequence generated for transistor VS1 ($G1$), respectively in the LabVIEW virtual instrument and in the MATLAB Simulink model. The results obtained from the

operation of the developed in LabVIEW virtual instrument match those obtained from the MATLAB Simulink model. The spectral compositions of the rectifier input currents differ from the results of the FFT analysis as the control PWM sequences are unipolar signals, which results in presence of even numbered harmonic components in their compositions.

V. CONCLUSION

The developed virtual instrument can be used for control and examination of the characteristics of three-phase bridge rectifiers with sinusoidal PWM. It can be used for realization of asynchronous rectifier control unit. The virtual instrument consists of modules realized as separate functional subunits (*subVI*). This allows variations in the operation principles of the virtual instrument and, thus, realization of different modifications of the control algorithm.

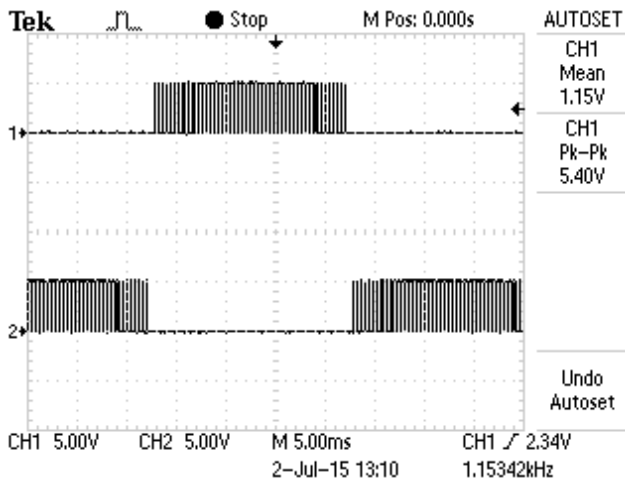
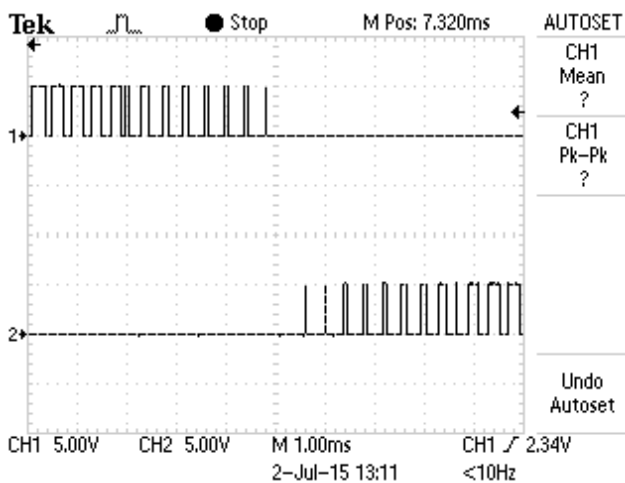
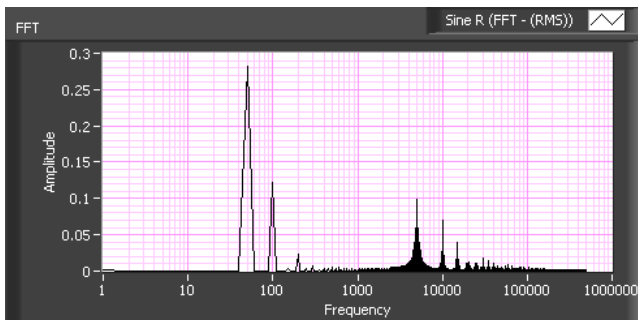
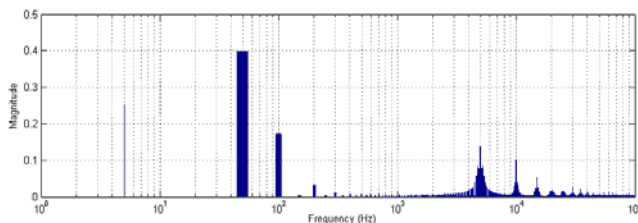
As a result from the operation of the virtual instrument, the Front Panel displays the waveforms of the grid voltages and the gate signals in an appropriate way for illustration of the input currents. These waveforms and the results from the FFT analysis of the gate signals provide the PFC features of the circuit with the presented control algorithm to be well comprehended.

The conducted analyses confirmed the limitations for the values of maximum allowed modulation depth and step of output voltage control imported by the parameters of the used hardware.

REFERENCES

- [1] P.M. Barbosa, Three-Phase Power Factor Correction Circuits for Low-Cost Distributed Power Systems, PhD diss., Virginia Polytechnic Institute and State University, 2002.
- [2] Power Factor Correction (PFC) Handbook, ON Semiconductor, Rev.4, Feb 2011, www.onsemi.com/pub/Collateral/HBD853-D.PDF
- [3] R.W. Erickson, Some Topologies of High Quality Rectifiers, First International Conference on Energy, Power, and Motion Control, May 5-6, 1997, Tel Aviv, Israel, (pp. 1-6).
- [4] T. Soeiro, T. Friedli, J. W. Kolar, SWISS Rectifier – A Novel Three-Phase Buck-Type PFC Topology for Electric Vehicle Battery Charging, Proceedings of the 27th Applied Power Electronics Conference and Exposition (APEC 2012), Orlando Florida, USA, February 5-9, 2012.
- [5] T. Soeiro, T. Friedli, J. W. Kolar, Three-Phase High Power Factor Mains Interface Concepts for Electric Vehicle Battery Charging Systems, Proceedings of the 27th Applied Power Electronics Conference and Exposition (APEC 2012), Orlando Florida, USA, February 5-9, 2012.
- [6] T. Nussbaumer, J.W. Kolar, Advanced Modulation Scheme for Three-Phase Three-Switch Buck-Type PWM Rectifier Preventing Mains Current Distortion Originating from Sliding Input Filter Capacitor Voltage Intersections, Power Electronics Specialist Conference, 2003. PESC'03, 2003 IEEE 34th Annual, vol. 3, pp. 1086-1091, 2003.
- [7] G. Kunov, S. Vuchev, Matlab-Simulink Model of Three-Phase BUCK Rectifier with Sinusoidal PWM, XLIX International scientific conference on information, communication and energy systems and technologies ICEST 2015, Serbia, Niš, June 25 - 27, 2014, vol. 2, pp. 479-482.