

ELECTRIC DETONATOR MEASURING EQUIPMENT

G. Stanchev, R. Arnaudov, R. Miletiev

Technical University of Sofia, 8 Kl. Ohridski Blvd, Sofia 1000, Bulgaria

Phone: (+359 2) 9652146, e-mail: RA@tu-sofia.bg

The test equipment is proposed and is elaborated to check single and grouped electric detonators with normal or enhanced electric stability (electric detonators class "N" and "P").

Keywords: electric detonator, measurement equipment

I. INTRODUCTION

The acceptance of the essential requirement regulation and the evaluation of the explosive compliance for civil applications, which introduce the Directive 93/15/EEC, demand the investigation and research processes to meet the European standard requirements in the civil engineering applications. The mines contain detonating gases and coal – dust while the electrical detonation systems are used such as an electric detonator. Their test consists in the measurement of some appointed parameters such as detonation time delay and their ability to explode by the fixed current pulse. The control parameter variety troubles the standard measurement equipment utilization and imposes the development of the special microprocessor controlled apparatus to test the electric detonators. It has to measure the detonator ohmic resistance, to control the continuous and pulse current mode endurance and detonation ability using reliable pulses and to measure the detonation time delay [1].

In order to guarantee the labour safety the explosives are subjected to strict control. Electric detonator is one of the components subject to such control. Its safety and reliability provide to a great extent the working personnel safety. For this reason, the basic parameters of every batch of electric detonators must be tested and checked.

II. MEASUREMENT EQUIPMENT DESCRIPTION

The developed equipment allows measuring the electric detonator ohmic resistance up to 2000Ω with an automatic range switching and maximum error $\pm 0.5\%$. It also may drive the detonators with a programmed DC current up to 0,5A and 300s continuance, programmed current pulses with amplitude up to 2A and 10ms duration and measures the detonation time delay with $1\mu\text{s}$ accuracy. The maximum time measure error and the maximum amplitude measurement error are equal to 0,1% and 1,0% respectively.

Blasting method is often used in coal and ore mining. Its typical feature is the building up of blowing up network of electric detonators as shown in Figure 1. The

showed resistances are expressed as follows: R_l – line resistance, R_{di} – electric detonator resistance.

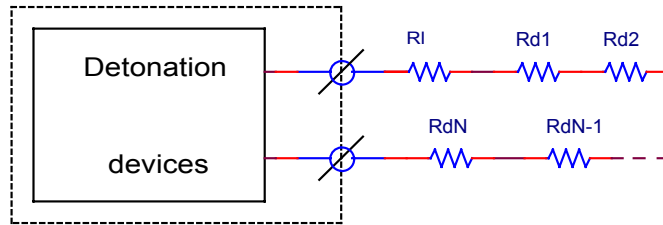

Figure 1. The detonation device

Block diagram of the proposed electric detonator testing stand is shown at Figure 2. It can be divided conditionally in two main sections: monitoring and control unit (microprocessor section) and power unit, which are separated and connected by optron network.

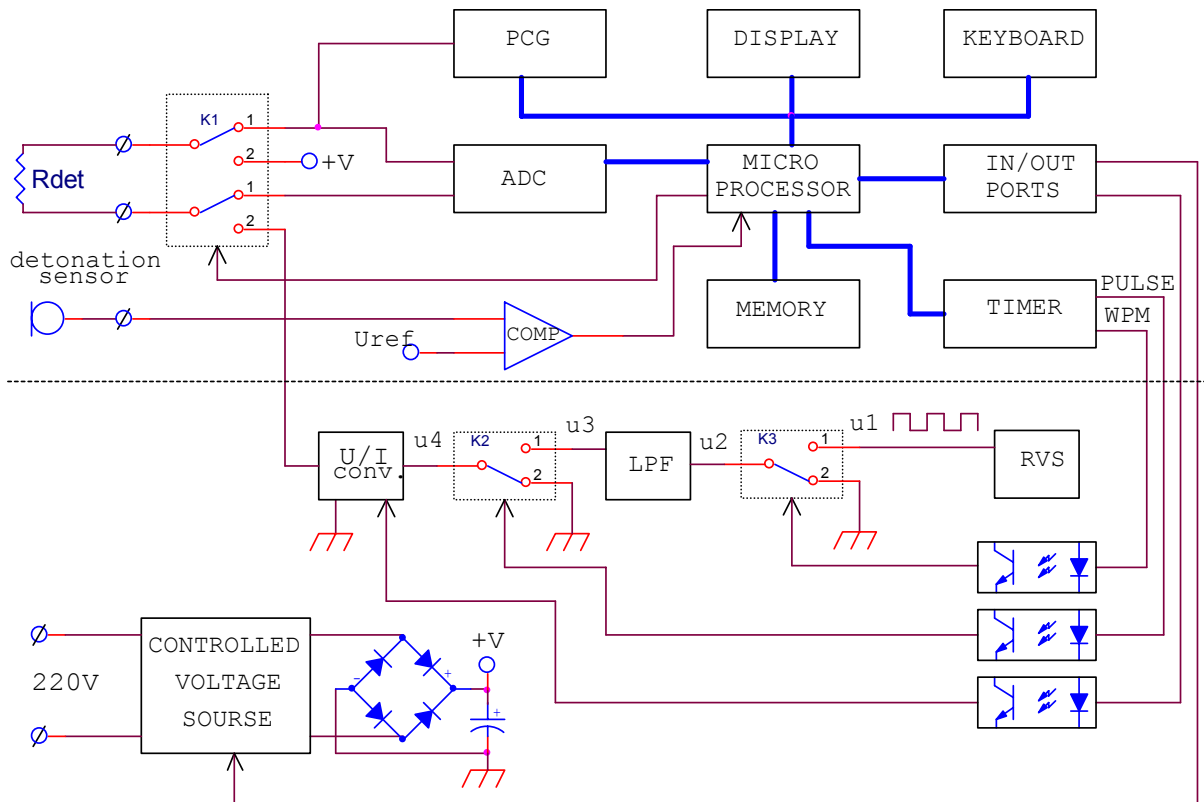

Figure 2. Block diagram

Microprocessor section consists of a Microprocessor (MP), Analog-to-Digital Converter (ADC), Programmable Current Generator (PCG), Comparator K, Memory, Display, Keypad, Input-Output I/O ports, Timer and Switch K1. The

parameters of different types of electric detonators can be entered and stored in the memory of electric detonator testing stand. This facilitates to a great extent the work of operator, who should preset only the type of tested electric detonators, and the stand itself determines what type of pulse to be fed for the different tests and whether the results obtained are within the required limits.

Power unit consists of a Driven (Controlled) Voltage Source, Rectifier, Voltage-Current Converter U/I, Reference Voltage Source, Low-Pass Filter (LPF), Optons and two switches K2 and K3.

The tested electric detonator, inserted in a explosion-proof chamber, a piezo-electric transducer and supply voltage 200 V are connected externally to the electric detonator testing stand.

III. ELECTRIC DETONATOR TESTING ALGORITHM

The blasting network is normally built up of a great number of electric detonators and, therefore, it is important to know their resistance, which should vary within the standard limits. The standards contain the resistance values of various types of electric detonators.

Main electric parameters of the electric detonator are described as follows:

- Electric detonator internal resistance R_{det} ;
- Positive blasting current i_{pos} ;
- Safe current i_{sc} ;
- Blasting energy at 1Ω resistance E_{1ohm} ;
- Detonation time delay t_{del} ;
- Pulse duration t_p .

1. Measuring the electric detonator internal resistance R_{det} .

Microprocessor MP switches K1 in position 1. The programmable generator feeds reference current through the electric detonator, the voltage drop on it is converted by the analog-to-digital converter ADC and measured by the microprocessor MP.

Detonator resistance is calculated according to the expression:

$$R_{det} = \frac{U_i}{I_{ref}}, \text{ where } U_i - \text{measured voltage drop, } I_{ref} - \text{reference current}$$

The resulted value appears on the display.

2. Feeding permanent safe current I_{ps} through the electric detonator for several minutes (Figure 4a).

Microprocessor MP switches K1 in position 2, selects supply voltage $U_{power} \geq I_{ps} R_{det}$ and sends a control signal to the driven voltage source. The timer, controlled by the microprocessor MP, generates two control signals PWM and

PULSE. These two signals define the duration and magnitude of the current pulse, respectively [2].

Signal PWM controls the multiplexer K3 feeding either the signal from reference voltage source or 0V to the low-pass filter LPF. Thus, the rectangular pulses from the reference voltage source are pulse width modulated. The modulated signal passes through the low-pass filter LPF, which amplitude output signal is proportional to the magnitude of current pulse (Figure 3).

The LPF input signal can be expressed using the well – known formula [3]:

$$U_2(t) = \frac{a_0}{2} + \sum_{k=1}^{\infty} a_k \cos k\omega_0 t + b_k \sin k\omega_0 t, \quad (1)$$

where $\omega_0 = 2\pi/T$ - angular frequency

T - signal period

a_k, b_k - Fourier coefficients

As the LPF rejects the signal frequency components except the direct component a_0 , the amplitude of the LPF output signal U_3 is calculated as follows:

$$U_3 = Ha_0 = H \frac{U_1}{T} \int_{t=0}^{\Delta T} U_2(t) dt, \quad (2)$$

where H – LPF amplitude response

ΔT – U_2 pulse duration

U_1 – Pulse amplitude, equal to the power supply voltage U_{cc}

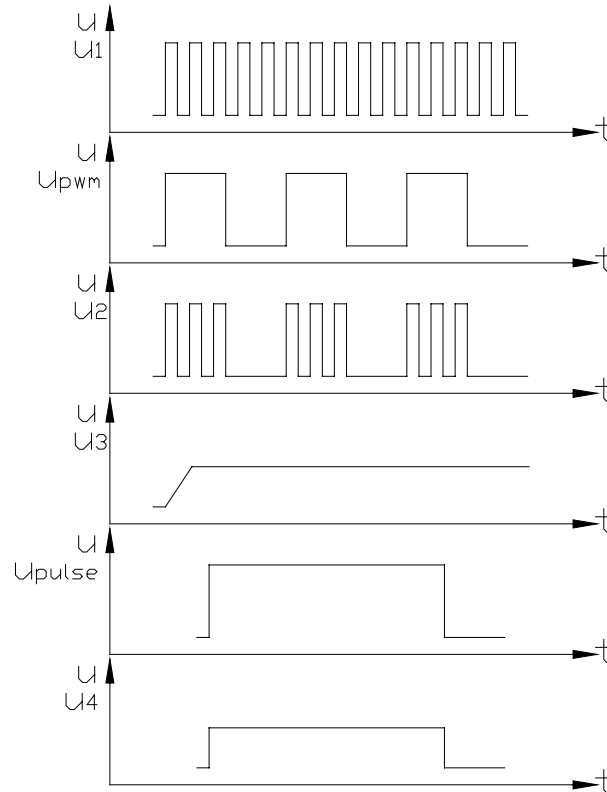

Figure 3. Pulse time diagram

If we assume that the U_1 period is equal to τ , the U_1 pulse duration is equal to $\tau/2$, then the LPF output amplitude is estimated according to the equation:

$$U_3 = H \frac{\Delta T}{2T} U_{cc} = \frac{\kappa H U_{cc}}{2}, \quad (3)$$

where $\kappa = \Delta T/T$ - pulse filling coefficient

Therefore the LPF output amplitude can be only adjusted if the microprocessor changes the κ coefficient. In this case the maximum output voltage is represented as:

$$(U_3)_{\max} = \frac{H U_{cc}}{2} \Big|_{\kappa=1}. \quad (4)$$

Signal PULSE controls the multiplexer K2 either feeding the signal from low-pass filter LPF or 0V to the voltage-current converter U/I. In this way the start and end points of the current pulse, fed to the electric detonator, are determined.

Voltage-current converter U/I is a voltage controlled current generator. It operates in two ranges and their switching is controlled by the microprocessor MP through input-output (I/O) ports. The high-voltage (current) circuit passes through +V Rectifier, the electric detonator internal resistance, U/I converter and ground (Figure 2).

When a safe current is fed to the electric detonator regardless the set period of time the detonation sensor should not register any detonation.

3. Feeding a safe pulse through the electric detonator

This current pulse has an amplitude $i > i_{sc}$ and duration $t_p < t_1$ (2 ms) (Figure 4b). The test runs similarly to that described in p. 2 above. The only differences are in the higher energy, and hence, the magnitude of current pulse ($i > i_{sc}$) and much shorter pulse $t_p < t_1$ approximately equal to 2 ms. No detonation should be registered by this test.

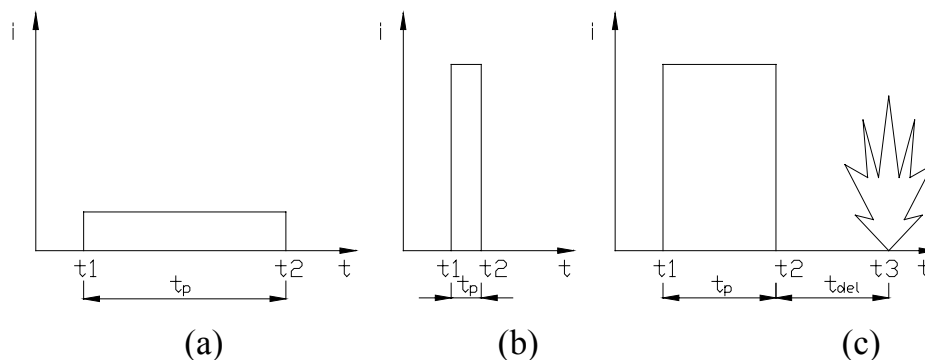

Figure 4. Current pulse time diagram

4. Feeding a positive current pulse (Figure 4c)

This current pulse has an amplitude $i_{pos} > i_{sc}$ and duration $t_1 < t < t_{kp}$ (4 ms). A current pulse with such parameters should cause detonation of the tested electric

detonator. Another important parameter is also measured using this test, i.e. the time delay of electric detonator t_{del} . It is determined by measuring the time period from feeding the signal pulse to the comparator switching, which registers the detonation in electric detonator.

IV. CONCLUSION

The test equipment is elaborated to check single and grouped electric detonators with normal or enhanced electric stability (electric detonators class "N" and "P"). The system single chip microcontroller allows combining the control software flexibility with the small equipment size. The I/O functions are realized by LCD or LED display, keyboard and RS232 interface to personal computer, which processes and stores the measurement data. The ohmic resistance measurement is accomplished by resistance to voltage conversion and analog-to-digital converter (ADC). The build-in timers set the current pulse duration and control the PWM (pulse width modulation) source to specify the pulse amplitude.

The galvanic separation of the power and control loops is realized by optocouples, which reduce the peak current pulses and electromagnetic noise. In the same time the external EEPROM memory may store the data of ten different detonator types and the stored parameters are load to the program memory before measurement tests.

IV. REFERENCES

1. Ministry of labour and social affairs. Regulation of security in the workplace during detonation work. Pub. NP N:3 from 10.01.1997.
2. Arnaudov R., G. Stanchev. Pulse Current Controller. ICEST'2002, Nish, Yugoslavia. Oktober 1 – 4. 2002.
3. Openhaim, A.V.; Willsky, A. S.; Young, I.T.: 'Signals and systems', *Prentice - Hall*, 1983